



# ITALIANA VALVOLE INDUSTRIALI TORINO

Produzione e vendita apparecchiature idrauliche e industriali

Saracinesca a ghigliottina motorizzata vite interna

Knife gate valve motorized non rising stem

PN: 10  
DN: 50-1200

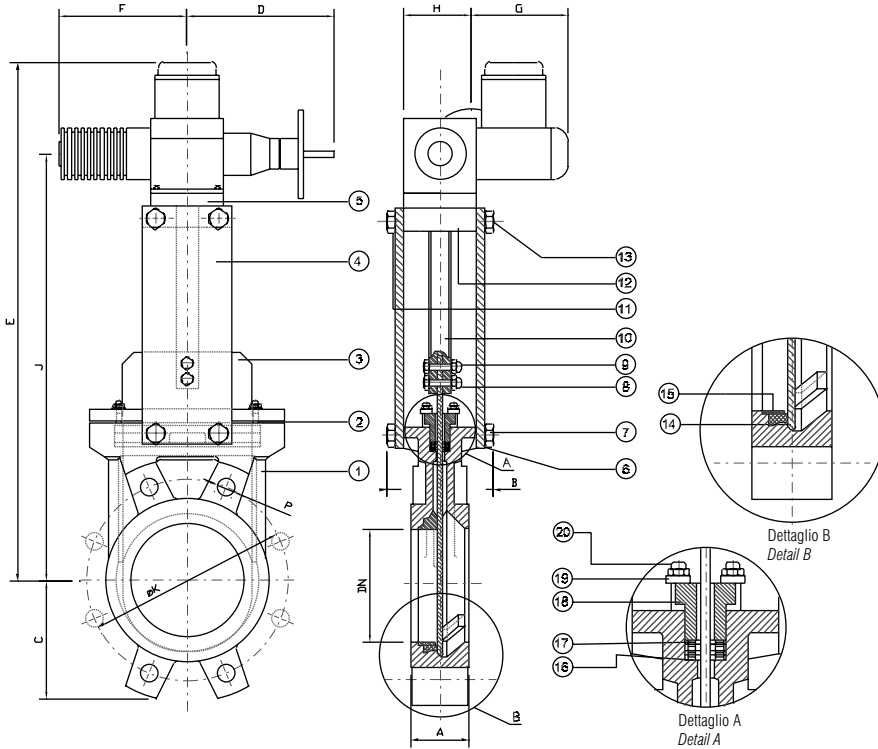

MATERIALI		
POS	DENOMINAZIONE	MATERIALE
1	CORPO	GJL 250 - GJS 400.15
2	GUARNIZIONE DI FISSAGGIO	ALLUMINIO
3	PARATIA	AISI 304
4	PIASTRA DI SUPPORTO	ACCIAIO
5	LUBRIFICATORE	STANDARD
6	BULLONI	ACCIAIO
7	VITI UNIONE PERNO-PARATIA	ACCIAIO
8	VITI UNIONE PERNO-PARATIA	ACCIAIO
9	PERNO	AISI 303
10	RONDELLA	ACCIAIO
11	SUPPORTO DI MANOVRA	ACCIAIO
12	DADO DI MANOVRA	BRONZO
13	VITE DI FISSAGGIO	AISI
14	TENUTA	NITRILE
15	ANELLO	AISI 316
16	PREMISTOPPA	TRECCIA LUBRIFICATA
17	GIUNTO TOROIDALE	NITRILE
18	VITE PRIGIONIERA	ACCIAIO
19	RONDELLA	ACCIAIO
20	VITE	ACCIAIO

DIMENSIONI DI INGOMBRO / DIMENSIONS												Pesi / Weight Kg
DN	A	B	C	D	E	F	G	H	J	ØK	P	
50	40	92	63	234	607	265	417	62	367	125	8	25
65	40	92	70	234	632	265	417	62	392	145	8	26
80	50	92	92	234	659	265	417	62	419	160	9	29
100	50	92	105	234	699	265	417	62	459	180	9	31
125	50	102	120	250	733	265	417	62	493	210	9	33
150	60	102	130	250	764	265	417	62	544	240	10	42
200	60	119	160	250	880	265	417	62	640	295	10	53
250	70	119	198	250	981	265	417	62	741	350	12	73
300	70	119	234	250	1141	265	417	62	841	400	12	85
350	96	194	256	256	1382	282	427	85	952	460	21	138
400	100	194	292	256	1558	282	427	85	1058	515	21	153
450	106	290	308	325	1886	385	465	90	1166	585	22	223
500	110	290	340	325	1991	385	465	90	1291	620	22	273
600	110	290	400	325	2197	385	465	90	1497	725	22	378
700	110	300	452	325	2565	385	465	90	1765	840	22	430
750	110	300	505	332	2715	385	465	90	1965	-	-	480
800	110	300	505	332	2780	385	465	90	1980	950	22	550
900	110	350	555	332	3045	385	465	90	2145	1050	20	670
1000	110	350	610	332	3350	385	465	90	2400	1160	20	750
1200	150	400	725	355	3960	510	465	115	2840	1380	22	880

MATERIALS		
POS	DENOMINATION	MATERIAL
1	BODY	EN GJL-250 - EN GJS-400-15
2	GASKET CLAMP	ALUMINIUM
3	GATE	AISI 304
4	SUPPORT PLATE	STEEL
5	GREASING	STANDARD
6	BOLTS	STEEL
7	MANOEUVERING BOLT	STEEL
8	MANOEUVERING PLUG	BRONZE
9	SPINDLE	AISI 303
10	GROWER WASHER	STEEL
11	MANOEUVERING SUPPORT	STEEL
12	MANOEUVERING NUT	BRONZE
13	STOP SCREW	AISI
14	SEAT	NITRILE
15	RING	AISI 316
16	PACKING	COTTON GREASED
17	TORIC JOINT	NITRILE
18	STUDS	STEEL
19	WASHER	STEEL
20	NUT	STEEL