



# ITALIANA VALVOLE INDUSTRIALI TORINO

Produzione e vendita apparecchiature idrauliche e industriali

Saracinesca a corpo ovale in ghisa -  
vite interna

Cast iron gate valve oval body -  
non-rising stem

PN: 16  
DN: 700-1200

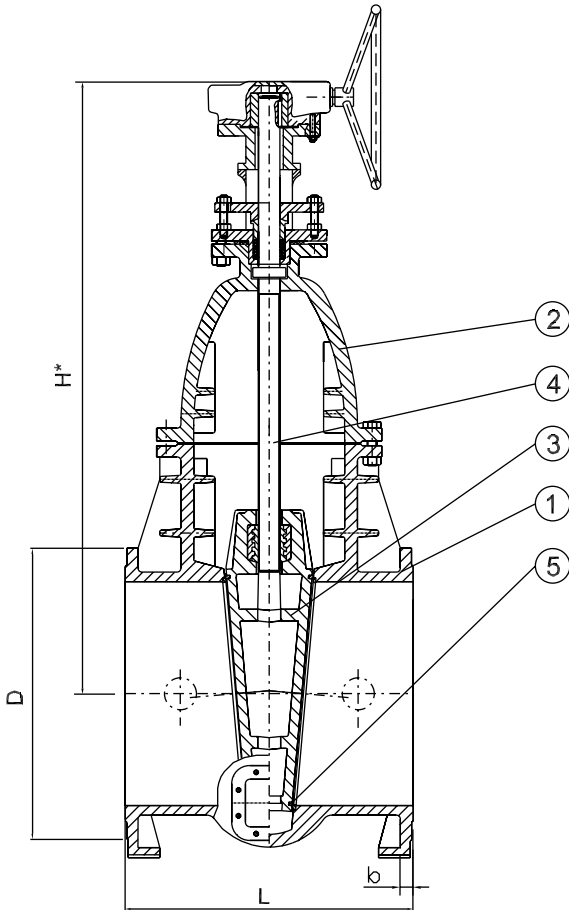

## MATERIALI

POS.	DENOMINAZIONE	MATERIALE
1	CORPO	GJL-250 (GJS-400-15)
2	COPERCHIO	GJL-250 (GJS-400-15)
3	CUNEO	GJL-250 (GJS-400-15)
4	STELO DI MANOVRA	ACCIAIO INOX X20 Cr13
5	SEDI DI TENUTA	OTTONE CuZn39 Pb2

## MATERIALS

POS.	DENOMINATION	MATERIAL
1	BODY	GJL-250 (GJS-400-15)
2	BONNET	GJL-250 (GJS-400-15)
3	WEDGE	GJL-250 (GJS-400-15)
4	STEM	STAINLESS STEEL X20 Cr13
5	SEAT	BRASS CuZn39 Pb2

## DIMENSIONI DI INGOMBRO / DIMENSIONS

DN	Foratura flange Drilling flanges	L	H*	PN	D	b	Peso /Weight Kg
700	PN10	900	1680	10	895	40	2060
800	PN10	1000	1980	10	1015	44	2600
900	PN10	1100	2095	10	1125	46	3060
1000	PN10	1200	2590	10	1230	50	4800
1200	PN10	838**	2960	10	1455	57	5670

H\* = Quote indicative / Indicative dimensions

\*\* DN1200 Special dimensions