



ITALIANA VALVOLE INDUSTRIALI TORINO

Produzione e vendita apparecchiature idrauliche e industriali

Valvola di ritegno a profilo VENTURI

Nozzle type check valve
VENTURI profile

PN: 64
DN: 40-300

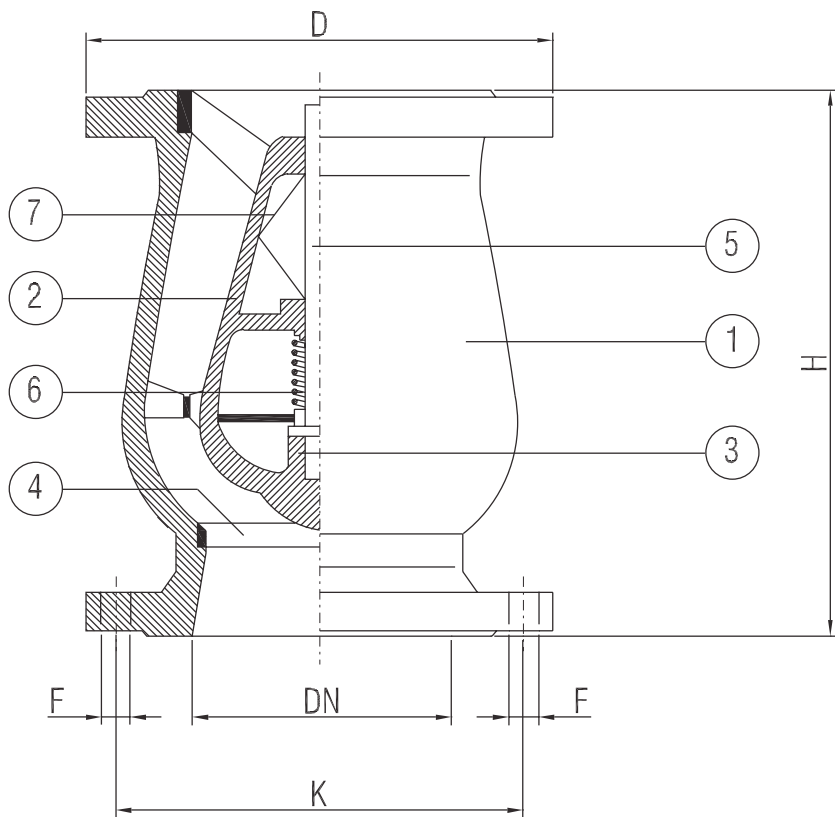

MATERIALI		
POS	DESCRIZIONE	MATERIALE
1	CORPO	EN GJL-250 (EN GJS-400-15)
2	OGIVA DN40/100	OTTONE
	OGIVA DN150/300	EN GJS-400-15
3	OTTURATORE DN40/125	OTTONE
	OTTURATORE DN150/300	EN GJS-400-15
4	SEGGIO CORPO	BRONZO o ACCIAIO INOX
5	STELO	ACCIAIO INOX 18/8
6	MOLLA	ACCIAIO INOX 18/8
7	STELO SU OGIVA OTTONE DN40/100	ACCIAIO INOX
	STELO SU OGIVA GHISA DN125/150	ACCIAIO INOX
	STELO SU BOCCOLA BRONZO DN200/400	ACCIAIO INOX

MATERIALS		
POS	DENOMINATION	MATERIALS
1	BODY	EN GJL-250 (EN GJS-400-15)
2	OGIVE DN40/100	BRASS
	OGIVE DN150/300	EN GJS-400-15
3	OBTURATOR DN40/125	BRASS
	OBTURATOR DN150/300	EN GJS-400-15
4	BODY SEAT	BRONZE /STAINLESS STEEL
5	STEM	STAINLESS STEEL 18/8
6	SPRING	STAINLESS STEEL 18/8
7	STEM ON BRASS OGIVE DN40/100	STAINLESS STEEL
	STEM ON CAST IRON OGIVE DN125/150	STAINLESS STEEL
	STEM ON BRONZE BUSH DN200/400	STAINLESS STEEL

DIMENSIONI DI INGOMBRO / DIMENSIONS							
DN	PN64					H	PESO /WEIGHT Kg
	D	K	F	n° fori / n° holes	M		
40	170	125	23	4	M20	120	7
50	180	135	23	4	M20	120	7
65	205	160	23	8	M20	150	11
80	215	170	23	8	M20	180	17
100	250	200	28	8	M24	240	23
125	295	240	31	8	M27	300	40
150	345	280	34	8	M30	350	54
200	415	345	37	12	M33	400	100