



ITALIANA VALVOLE INDUSTRIALI TORINO

Produzione e vendita apparecchiature idrauliche e industriali

Giunti di smontaggio a tre flange
'ACMO-JOINT' in Acciaio al Carbonio

Dismantling pieces three flanges
'ACMO-JOINT' in Carbon Steel

PN: 64
DN: 40-600

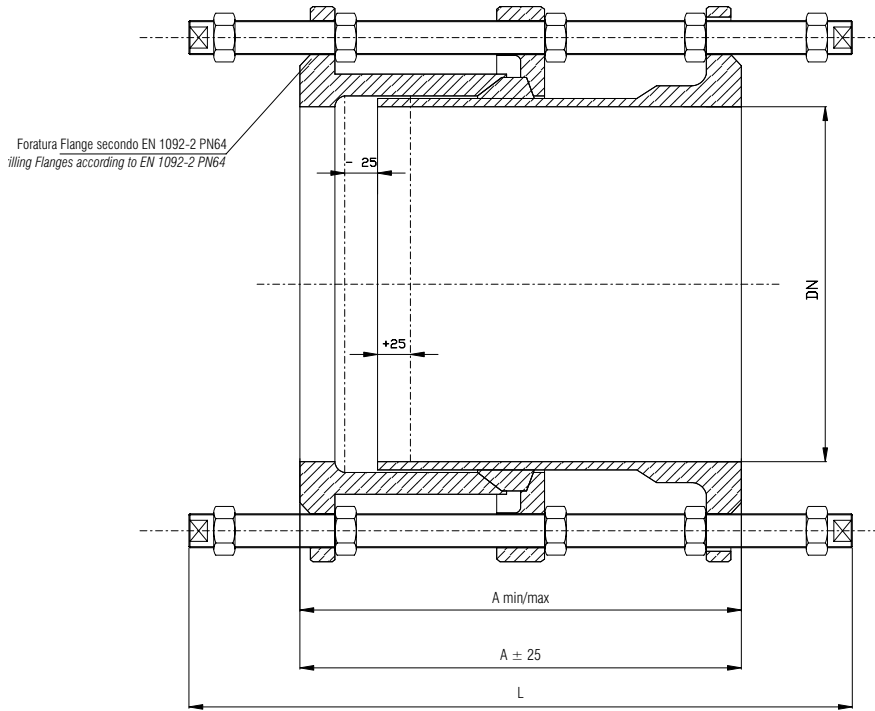

MATERIALE		
POS	DENOMINAZIONE	MATERIALE
1	CORPO	ACCIAIO AL CARBONIO FE 37
2	FLANGE	ACCIAIO AL CARBONIO FE 37
3	TIRANTI E BULLONI	ACCIAIO AL CARBONIO GALVANIZZATO (A RICHIESTA ACCIAIO INOX)
4	GUARNIZIONE	NBR ATOSSICA
5	RIVESTIMENTO	VERNICE EPOSSIDICA ATOSSICA (A RICHIESTA ZINCATURA A CALDO)

MATERIALS		
POS	DENOMINATION	MATERIALS
1	BODY	CARBON STEEL FE 37
2	FLANGES	CARBON STEEL FE 37
3	CONNECTING RODS	GALVANIZED CARBON STEEL (STAINLESS STEEL ON REQUEST)
4	PACKING	NBR
5	COATING EPOXY	EPOXY (GALVANIZED ON DEMAND)

DIMENSIONI DI INGOMBRO / DIMENSIONS							
DN	A	L	FORI HOLES	TIRANTI CONN. RODS	DADI TIRANTI NUTS SCREWS		
mm	mm	mm	N°	D	N°	D	N°
40	210	350	4	M20	4	M20	20
50	210	350	4	M20	4	M20	20
65	210	350	8	M20	8	M20	40
80	230	370	8	M20	8	M20	40
100	240	380	8	M24	8	M24	40
125	260	420	8	M27	8	M27	40
150	280	440	8	M30	8	M30	40
175	290	460	12	M33	12	M33	60
200	310	490	12	M33	12	M33	60
250	320	510	12	M33	12	M33	60
300	320	530	16	M33	16	M33	80

DIMENSIONI DI INGOMBRO / DIMENSIONS							
DN	A	L	FORI HOLES	TIRANTI CONN. RODS	DADI TIRANTI NUTS SCREWS		
mm	mm	mm	N°	D	N°	D	N°
350	350	570	16	M36	16	M36	80
400	360	590	16	M39	16	M36	80
500	420	680	20	M39	20	M39	100
600	450	750	20	M45	20	M45	100