



ITALIANA VALVOLE INDUSTRIALI TORINO

Produzione e vendita apparecchiature idrauliche e industriali

Filtro di presa

Suker

PN: 10

DN: 50-500

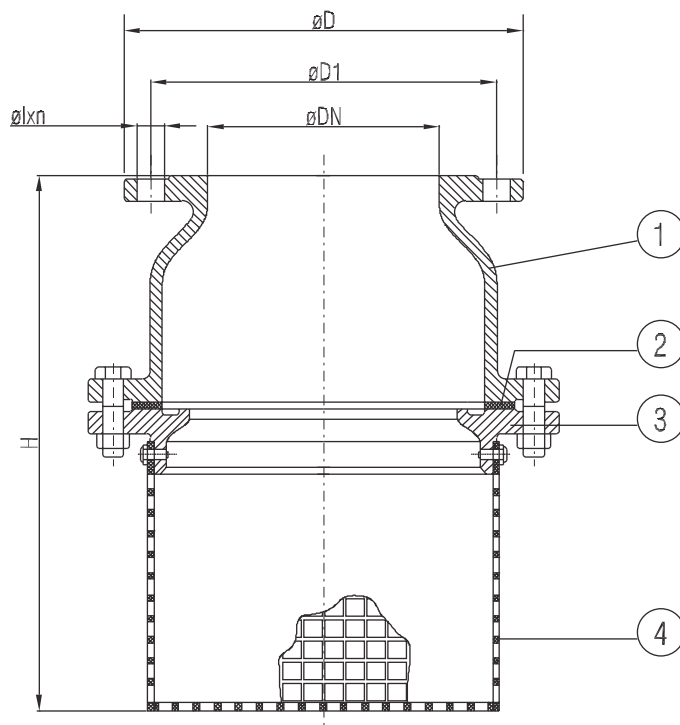
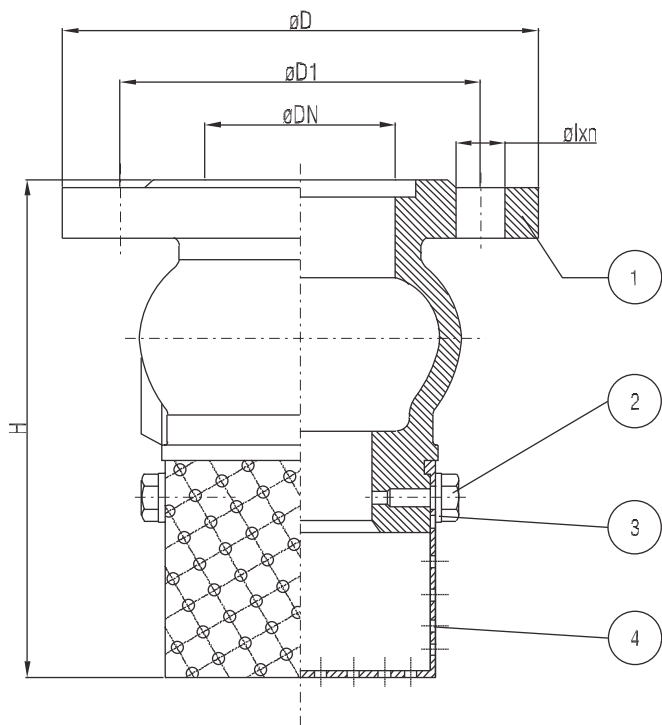

MATERIALI		
POS	DENOMINAZIONE	MATERIALE
1	CORPO	EN GJL-250 o EN GJS-400-15 o ACCIAIO INOX AISI 304
2	DADO	ACCIAIO AL CARBONIO
3	RONDELLA	ACCIAIO AL CARBONIO
4	GRIGLIA	ACCIAIO INOX AISI 304

MATERIALS		
POS	DENOMINATION	MATERIAL
1	BODY	EN GJL-250 or EN GJS-400-15 or STAINLESS STEEL AISI 304
2	NUTS	CARBON STEEL
3	WASHER	CARBON STEEL
4	GRID	STAINLESS STEEL AISI 304

DIMENSIONI DI INGOMBRO / DIMENSIONS						
DN	$\varnothing D$	$\varnothing D1$	H	n	$\varnothing l$	
50	165	125	166	4	18	
65	185	145	201	4	18	
80	200	160	221	4	18	
100	220	180	265	8	18	
125	250	210	300	8	18	
150	285	240	360	8	22	
200	340	295	470	8	22	
250	395	350	568	12	22	
300	445	400	653	12	22	
350	505	470	785	16	22	
400	565	525	900	20	27	
500	670	620	1125	20	28	